

(Model.)

E. PEMENT.
LATHE CHUCK.

No. 322,636.

Patented July 21, 1885.

Fig. 1.

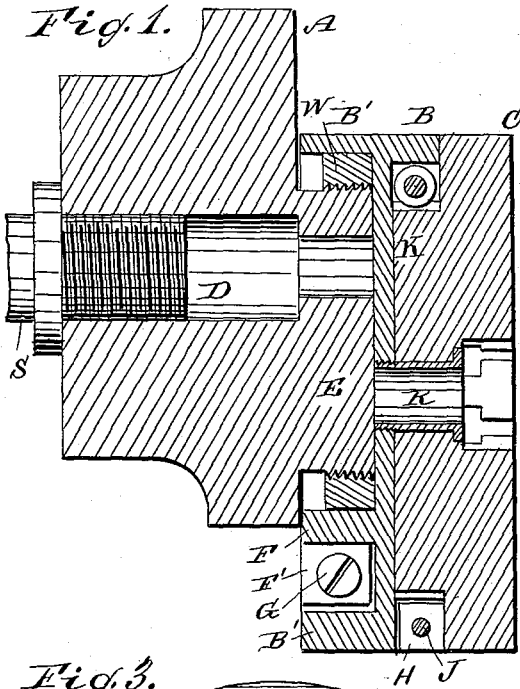

Fig. 2.

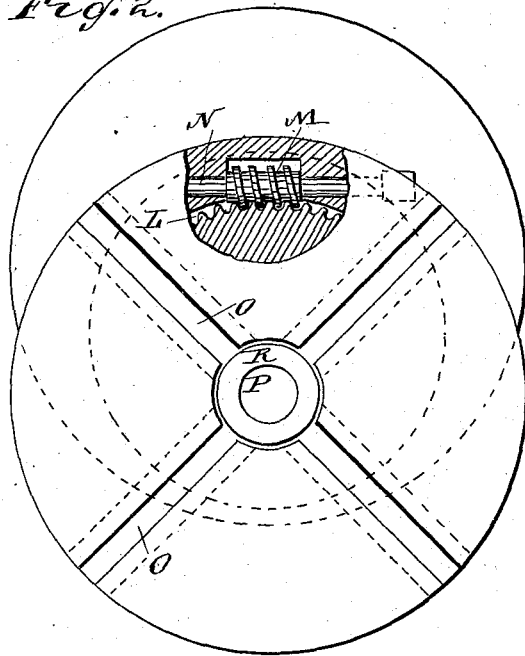

Fig. 3.

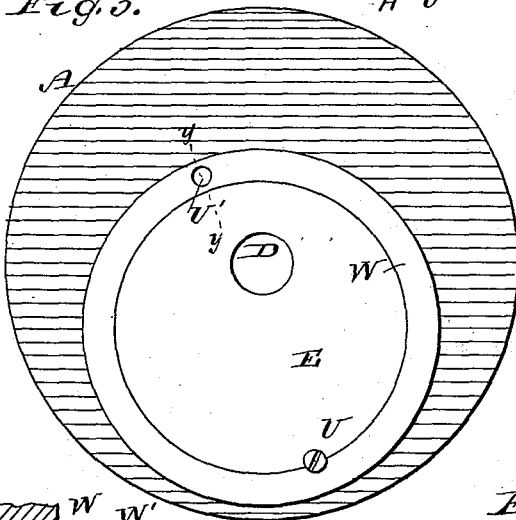

Fig. 4.

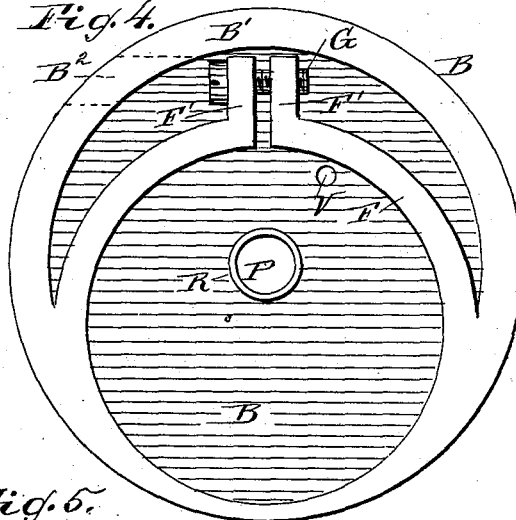

Fig. 5.

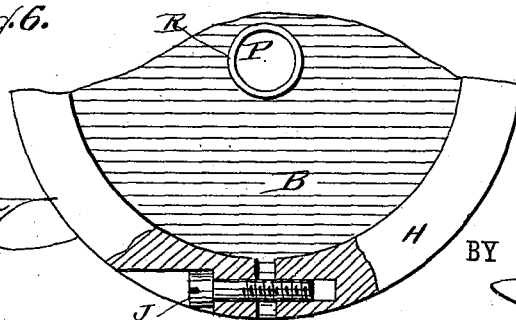
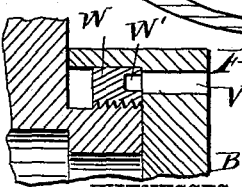

Fig. 6.



WITNESSES:

Geo. G. Weston
C. Sedgwick

INVENTOR:

E. Pement

BY

Munn & Co

ATTORNEYS.

UNITED STATES PATENT OFFICE.

EDWARD PEMENT, OF ESMOND, DAKOTA TERRITORY.

LATHE-CHUCK.

SPECIFICATION forming part of Letters Patent No. 322,636, dated July 21, 1885.

Application filed April 14, 1885. (Model.)

To all whom it may concern:

Be it known that I, EDWARD PEMENT, of Esmond, in the county of Kingsbury and Territory of Dakota, have invented a new and Improved Face-Plate and Lathe-Chuck Attachment, of which the following is a full, clear, and exact description.

The object of my invention is to provide a new and improved face-plate and chuck attachment, by means of which the operator is enabled to bring any point on the face of his work to the center very easily and rapidly.

The invention consists in the construction, arrangement, and combination of parts and details, as will be fully set forth and described hereinafter.

Reference is to be had to the accompanying drawings, forming part of this specification, in which similar letters of reference indicate corresponding parts in all the figures.

Figure 1 is a longitudinal sectional elevation of my improved face-plate and chuck attachment. Fig. 2 is a face view of the same, parts being broken out and others in section. Fig. 3 is a face view of the inner section. Fig. 4 is an inside face view of the middle section. Fig. 5 is a longitudinal sectional view of the lower part of the middle section. Fig. 6 is a detail sectional view on the line *y y*, Fig. 3.

My improved attachment consists of the inner section, A, the middle section, B, and the outer section, C. The inner section, A, which consists of a chuck-disk, has a central screw-threaded bore, D, and is provided on its outer end with an eccentric projection, E, upon which is cut a screw-thread extending from the outer end of said projection or eccentric inwardly and occupying about two-thirds (more or less) of its circumference. A collar, W, is screwed on the said projection, and upon the collar is fitted a flange of the split collar F, the free end of which flange extends to the section A. The collar W is provided with recesses W' for receiving the end of a screw or pin, U, which is passed through an aperture, V, in the rim B' of the section B to prevent the collar W from unscrewing from the projection E. An aperture, U', is provided in the rim B' and in the collar W for receiving a punch or other implement for turning the section B and the collar W to screw the latter on the projection E.

By means of the above device the operator is enabled to move the section B to either side without endangering the heavy or light work when he loosens the screw G, passed through the end lugs, F', of a split spring-collar, F, formed eccentrically on the inner surface of the section B. The screw G serves to clamp the split collar F about the collar W. The rim B' of the section B has an aperture, B², through which the screw-driver can be passed for turning the said screw G. A split collar, H, is formed on the lower part of the section B, on the outer surface of the same, and through the ends of the said split collar a screw, J, is passed for clamping the collar on the circular projection K on the inner surface of the outer section, C. A worm-thread, L, is cut in parts of the rim of the projection K, and engages with a worm, M, formed on a spindle, N, in the section B. The section C has the grooves O for the chuck-jaws. The sections B and C have concentric central bores, P. A hollow bolt, R, is screwed in the bores of the sections B and C. The bolt R is made hollow, so as to permit a center being used whenever required. The section A is screwed on the lathe-spindle S, or on the spindle of any other machine on which the attachment can be used effectually. When the screw J is loosened, the section C can be turned on the section B by means of the worms M N, and then locked in place by the screw J. By turning the section B on the section A it is moved laterally and vertically at the same time, and can be locked in place by means of the screw G.

Having thus described my invention, what I claim as new, and desire to secure by Letters Patent, is—

1. In a face-plate and chuck attachment, the combination, with the section A, having a projection, E, which is screw-threaded on its rim, of a screw-collar, W, screwed on the said projection, and the section B, which is clamped on the collar W, substantially as herein shown and described.

2. In a face-plate and chuck attachment, the combination, with the section A, having the eccentric projection E, the rim of which is screw-threaded, of the screw-collar W and the section B, the said section B and the screw-collar being provided with apertures for receiving

screws, and implements for turning the said collar, substantially as herein shown and described.

3. In a face-plate and chuck attachment, the sections A, B, and C, combined substantially as herein shown and described.

4. In a face-plate and chuck attachment, the combination, with the section A, having the eccentric projection E, of the sections B and C, substantially as herein shown and described.

5. In a face-plate and chuck attachment, the combination, with the section A, having the eccentric projection E, of the section B, having the split collar F, and of the screw G, substantially as herein shown and described.

6. In a face-plate and chuck attachment, the combination, with the section B, having the split collar H, of the screw J, the section C, having the projection K, and of the worm M on the spindle N, substantially as herein shown and described.

7. In a face-plate and chuck attachment, the combination, with the section A, having the eccentric projection E, of the section B, having the split collars F and H, the screws G and J, and of the section C, substantially as described.

EDWARD PEMENT.

Witnesses:

W. H. HUMPHREY,
PETER WEST.